

CONDOMINIUM DECLARATION

FOR

CAMELOT TOWNHOMES

THIS CONDOMINIUM DECLARATION OF COVENANTS, CONDITIONS AND RESTRICTIONS, made this 1st day of September, 1978 by SIERRA PROPERTIES, INC., a Texas Corporation, hereinafter referred to as "DECLARANT":

W I T N E S S E T H:

1. RECITALS AND DECLARATION:1.1 Recitals.

(a) DECLARANT is the owner of the following described real estate together with the improvements thereon located in El Paso County, Texas, to-wit:

A. Fee.

A 3.161 acre parcel of land out of Lot 8, Camelot Heights and a portion of the F.W. Brown Survey No. 224, City of El Paso, El Paso County, Texas, more particularly described by metes and bounds on Exhibit "A" attached hereto;

B. Nonexclusive Easement.

All of Declarant's right, title and interest in and to a nonexclusive easement from William F. Farah and wife Betty Farah, dated the 26th day of July, 1978.

C. Amenities Agreement.

All of the rights, duties, and obligations of Declarant in, to and under a contract between William F. Farah, Betty Farah and Declarant dated July 26, 1978,

such land and improvements thereon being hereinafter collectively referred to as the "Project".

(b) DECLARANT desires to submit the Project to a condominium regime pursuant to the terms and provisions of the Texas Condominium Act, Article 1301(a), Vernon's Annotated Texas Statutes (the "Act").

1.2 Declaration.

(a) DECLARANT does hereby declare the Project to be a condominium regime, pursuant to the Act, which shall be known as Camelot Townhomes. The Project shall hereafter be subject to the covenants, restrictions, limitations, conditions and

uses of this Declaration, which shall run with the land, shall be binding upon Declarant, its successors and assigns, and any person or entity acquiring an interest in the Project, their grantees, successors, heirs, executors, administrators, devisees or assigns.

(b) DECLARANT, in order to establish a plan of condominium ownership, hereby covenants and agrees that it hereby divides the Project into the following separate freehold estates:

(1) Thirty three (33) separately designated and legally described freehold estates hereinafter defined and referred to as "Units"; and

(2) A freehold estate consisting of the remaining portion of the real property hereinafter defined and referred to as the "Common Areas";

all as more particularly described on Exhibit "C" attached hereto and made a part hereof for all purposes (the "Map").

2. DEFINITIONS.

As used herein or elsewhere in any documents affecting the Project unless otherwise provided or unless the context requires otherwise, the following terms shall be defined as in this Article provided:

2.1 Project. The "Project" refers to and means the entire real estate described in Exhibit "A", divided into Condominiums, including all structures thereon, and the Common Areas and Units within said real estate description.

2.2 Condominium. "Condominium" shall mean a condominium as defined in the Act, and shall be an estate in real property consisting of (a) a separate fee interest in the space within a Unit, and (b) an undivided interest as a tenant in common in the Common Areas. Additionally, each Owner of a Condominium shall receive a membership in CAMELOT TOWNHOMES ASSOCIATION, INC.

2.3 Unit. "Unit" shall mean and refer to the elements of a Condominium which are not owned in common with other Owners of other Condominiums. The boundaries of a Unit shall be the interior surfaces of the perimeter walls, floors, ceilings,

windows and doors of each Unit. The Unit shall include both the portions of building so described and the air space so encompassed. In interpreting deeds and plans, the existing physical boundaries of a Unit, or of a Unit reconstructed in substantial accordance with the original plans shall be conclusively presumed to be its boundaries, rather than the metes and bounds, or other description, expressed in the deed or plan, regardless of settling or lateral movement of the building and regardless of minor variances between boundaries shown on the plan or in the deed of those of a building.

In addition, "Owners" of units 19 and 33 will receive land adjacent to their units as shown on "Exhibit C" (the map) as areas 19A and 33A, for the purposes of future enlargement of their respective units. Future enlargements will be defined as "Unit". All nonconstructed portions of areas 19A and 33A will become "Limited Common Areas."

2.4 Owner. An "Owner" shall mean and refer to the record owner, whether one or more persons or entities, of a Condominium which is a part of the Project, including contract sellers, but excluding those having such interest merely as a security for the performance of an obligation.

2.5 Common Areas. "Common Areas" shall mean and refer to the entire Project, excepting those portions thereof which lie within the boundaries or comprise a part of any Unit, as hereinabove defined.

2.6 Limited Common Areas and Facilities. "Limited Common Areas" shall mean a portion of the Common Areas set aside and allocated for the exclusive use of the respective Units or Owners, as shown on Exhibit "C".

2.7 Association. "Association" shall mean and refer to CAMELOT TOWN-HOMES ASSOCIATION, INC., a non-profit corporation, its successors and assigns.

2.8 Common Assessment. A "Common Assessment" shall mean and refer to that portion of the cost of maintaining, improving, repairing and managing the Project, and all other "Common Expenses" as provided herein which is charged to the Owner of each respective Condominium.

2.9 Special Assessment. A "Special Assessment" shall mean and refer to a charge against a particular Owner and his Condominium equal to the cost incurred by the Association for corrective action performed pursuant to provisions of this Declaration and of the By-Laws of the Association.

2.10 Mortgage. "Mortgage" shall mean the conveyance of any Condominium or other portion of the Project to secure the performance of an obligation, which conveyance shall be released or reconveyed upon the due performance of said obligation, and shall include a deed of trust.

2.11 Mortgagee and Mortgagor. "Mortgagee" shall mean a person or entity to whom a Mortgage is made and shall include the beneficiary of a deed of trust; "Mortgagor" shall mean a person or entity who mortgages his or its property to another, or who conveys his or its property to another by a deed of trust.

2.12 Declarant. "DECLARANT" shall mean and refer to SIERRA PROPERTIES, INC., its successors and assigns.

2.13 Common and Special Expenses.

2.13.1 "Common Expenses" shall mean (a) the expenses of, or reasonable reserves for, the maintenance, management, operation, repair and replacement of the Common Areas as to which it is the responsibility of the Association to maintain, repair and replace, including the cost of unpaid Special Assessments;

(b) the cost of capital improvements to the Common Areas which the Association may from time to time authorize; (c) the expenses of management and administration of the Association, including without limitation, compensation paid or incurred by the Association to a manager, accountants, attorneys, or other employees or agents; and (d) any other item or items designated by or in accordance with other provisions of this Declaration or By-Laws of the Association to be Common Expenses, and any other expenses reasonably incurred by the Association on behalf of all Owners.

2.13.2 "Special Expenses" shall mean (a) the expenses incurred by the Association for the repair of damage or loss to

the Common Areas or the property of other Owners caused by the act or neglect of an Owner which is not covered or fully covered by insurance; (b) the expense of repair of reconstruction of a building damaged or destroyed by fire or other casualty for which there shall be insufficient or no insurance coverage and the repair of which will directly benefit less than all of the Owners; and (c) any other item or items designated by or in accordance with other provisions of this Declaration or the By-Laws of the Association to be Special Expenses.

2.14 Building. Unless otherwise indicated by the context, "Building" shall mean a single building containing Units as shown on the Map.

2.15 Member. "Member" shall mean and refer to every person or entity who holds membership in the Association.

2.16 Acceptance of Deed. "Acceptance of a deed", or similar language, as used herein shall mean either (i) joining in the execution of such deed or (ii) causing same to be recorded, regardless of whether the grantee joins in the execution thereof.

3. THE PROJECT AND ASSOCIATION MEMBERSHIP.

3.1 Covenants. DECLARANT, its successors and assigns, by this Declaration, and all future Owners of the Unit, by their acceptance of their deeds, covenant and agree as follows:

(a) That the Units shall be occupied and used by the respective Owners only as a private dwelling for the Owner, his family, tenants and social guests and for no other purpose. No Owner of a Unit shall be permitted to rent his Unit for transient or hotel purposes. No Owner of a Unit may lease less than his entire Unit. Any lease agreement shall be required to provide that the terms of the lease shall be subject in all respects to the provisions of the DECLARATION and the By-Laws of the Association, and that any failure by the Lessee to comply with the terms of such DECLARATION and By-Laws shall be

a default under the lease. All leases shall be in writing, and a copy thereof shall be filed with the Association. Other than the foregoing; there is no restriction on the right of any Owner of a Unit to lease same.

(b) That the Owner of each respective Unit shall not be deemed to own the undecorated and/or unfinished surfaces of the perimeter walls, floors, and ceilings surrounding his respective Unit, nor shall said Owner be deemed to own pipes, ducting, wires, conduits or other public utility lines running through said respective Unit, which are utilized for, or serve more than one Unit, except as a tenant in common with the other Owners. An Owner, however, shall be deemed to own the walls and partitions which are contained within the Owner's respective Unit (but no structural changes therein shall be permitted without the Association's consent as provided in its By-Laws), and also shall be deemed to own the interior decorated and/or finished surfaces of the perimeter walls, floors and ceilings, including paint, wallpaper, etc.

(c) That the administration of the Project shall be in accordance with the provisions of this Declaration, the Articles of Incorporation of the Association, a copy of which is attached hereto as Exhibit "B" and made a part hereof, and the By-Laws of the Association.

3.2 Membership. Every person or entity who is an Owner of a Condominium which by virtue of the Declaration is subject to assessment by the Association, shall be a Member of the Association. The foregoing is not intended to include persons or entities who hold an interest merely as security for the performance of an obligation. No Owner shall have more than one membership per unit. Membership shall be appurtenant to and may not be separated from the ownership of any Condominium which is subject to assessment by the Association. Ownership of such Condominium shall be the sole qualification for membership.

3.3 Transfer. The membership held by an Owner of a Condominium shall not be transferred, pledged or alienated in any way, except upon the sale or encumbrance of such Condominium, and then only to the purchaser or mortgagee of such Condominium. Any attempt to make a prohibited transfer is void, and will not be reflected upon the books and records of the Association. In the event the Owner of any Condominium should fail or refuse to transfer the membership registered in his name to the purchaser of such Condominium, the Association shall have the right to record the transfer upon the books of the Association and shall issue a new informal certificate to the purchaser, and thereupon the old certificate outstanding in the name of the seller shall be null and void as though the same had been surrendered.

4. VOTING RIGHTS.

4.1 The Association shall have two classes of voting membership with the voting rights hereinafter indicated:

Class A Members. Class A Members shall be all Owners with the exception of DECLARANT and shall be entitled to one (1) vote for each Condominium in which they hold the interest required for membership. When more than one person holds such interest or interests in any Condominium all such persons shall constitute one member, and the one vote for such Condominium shall be exercised as they among themselves shall determine, but in no event shall more than one vote be cast with respect to any such Condominium.

Class B Members. DECLARANT, and its successors and assigns shall be a Class B Member and shall be entitled to four (4) votes for each Condominium owned. The Class B Membership shall cease and be converted to Class A Membership upon the happening of either of the following events, whichever occurs earlier:

(i) When the total votes outstanding in the Class A Membership equals the total votes outstanding in the Class B Membership; or

(ii) On December 31, 1980.

Transfer of title to a Condominium by DECLARANT to another entity which does not constitute a sale or sales to individual owner residents shall not convert DECLARANT'S Class B Membership into a Class A Membership.

4.2 Voting Rights. The voting rights provided in this Article 4 shall be subject to the restrictions and limitations provided hereinafter and in the Articles and By-Laws of the Association.

4.3 Original Board of Directors. Notwithstanding anything in this Declaration to the contrary, the original Board of Directors of the Association shall be three (3) in number. Commencing at the time of recordation of this Declaration and until successors are elected pursuant to the provisions of the By-Laws of the Association, said original Board of Directors shall be composed of:

Charles C. Wood
James Sorenson
William J. Mounce

During the above period of time, members of the Board shall serve at the pleasure of DECLARANT and may be removed from office at any time by DECLARANT and during said period DECLARANT shall have authority in its sole discretion to fill any vacancies created or existing on said Board.

5. COMMON AREAS.

5.1 Percentage of Ownership. The Common Areas shall be owned by each Owner as a tenant in common in the percentage interest designated and assigned to each Unit in Exhibit "D" attached hereto, which is made a part hereof. The respective undivided interests in the Common Areas hereby established are to be conveyed with the respective Units and cannot be separated therefrom. Each undivided interest shall be deemed to be conveyed or encumbered with its respective Unit even though the description in the conveyance or mortgage may refer only to the fee title to the Unit.

5.2 Members' Easements of Enjoyment. Every Member shall have a right and non-exclusive easement of enjoyment in and to the Common Areas, (but not to the Limited Common Areas) and such easement shall be appurtenant to and shall pass the title to every assessed Condominium, subject to the following provisions:

(a) The right of the Association to limit or exclude the number of guests of Members.

(b) The right of the Association to establish uniform rules and regulations pertaining to the use of the Common Areas and the recreational facilities thereon.

(c) The right of the Association to charge reasonable admission and other fees for the use of any recreational facility situated upon the Common Areas.

(d) The right of the Association to suspend the voting rights and the right to the use of water and other utilities and/or other facilities of the Common Areas by a Member for any period during which any assessment against his Condominium remains unpaid and delinquent; and for a period not to exceed thirty (30) days for any single infraction of the rules and regulations of the Association, provided that (i) the Owner's right to use utilities shall be suspended only in the event of unpaid assessments and/or for infraction of rules and regulations; and (ii) any suspension of such voting rights or right to use said utilities and/or other facilities of Common Areas shall be made only by the Board of Directors of the Association after 10 days written notice and hearing given and held in accordance with the By-Laws of the Association. By acceptance of a deed to any Condominium in this Project, the Owner does hereby irrevocably give and grant unto the Association, its agents and employees, a power of attorney, in his place and stead, to disconnect or take other appropriated steps to discontinue the Owner's use of the public utilities serving his respective

Unit in the case of any such suspension.

5.3 Members' Easements of Ingress, Egress and Support.

Every Member shall have a right and non-exclusive easement for ingress, egress and support through the Common Areas, except the limited Common Areas, and such easement shall be appurtenant to and shall pass with title to every assessed Condominium.

5.4 Delegation of Use. Any Member may delegate in accordance with the By-Laws, his right of enjoyment to the Common Areas to the members of his family who reside with him in his Condominium, and to his tenants or contract purchasers who reside in his Condominium.

5.5. Waiver of Use. No Member may exempt himself from liability for assessments duly levied by the Association, nor release the Condominium owned by him from the liens and charges hereof, by waiver of the use and enjoyment of the Common Areas and the facilities thereon or by abandonment of his Condominium.

5.6. Additional Provisions Relating to Common Areas and Units. DECLARANT, its successors and assigns, all future Owners of the Condominiums, by their acceptance of their respective deeds, covenant and agree as follows:

(a) That the Common Areas except to limited Common Areas shall remain undivided; and no Owner shall bring any action for partition, it being agreed that this restriction is necessary in order to preserve the rights of the Owners with respect to the operation and management of the Project.

(b) That if any portion of the Common Areas encroaches upon the Units, a valid easement for the encroachment and for the maintenance of same, so long as it stands, shall and does exist. In the event a building is partially or totally destroyed and then rebuilt, the Owners of Units agree that minor encroachments of parts of the Common Areas due to construction shall be permitted and that valid easements for said encroachment and the maintenance thereof shall exist.

(c) That the Common Areas are and shall always be subject to easements for minor encroachments thereof of the Unit and that a non-exclusive easement for ingress, egress and support through the unrestricted Common Areas is appurtenant to each Unit and the Common Areas are subject to such easements.

(d) That the Association shall have the responsibility (subject to the provisions of Article 6 hereof) to manage and maintain all of the Common Areas, including without limitation the exteriors of all buildings, landscaping and the private driveways, except for maintenance to be provided by "Owner" as described in section 8.1.3 Duties of Owners, and such maintenance shall be of a high quality so as to keep the entire Project in first class condition and in a good state of repairs; provided, however, that each Owner shall have the exclusive right to paint, repaint, tile, wax, paper or otherwise refinish and decorate the inner surfaces of the walls, ceilings, floors, windows and doors bounding his own Unit.

(e) That the Association shall employ a Manager to perform such duties and services as the Board of Directors shall direct, including, but not limited to, the performance of all obligations of the Association with respect to the Common Areas, and the receipt, discharge and accounting for all assessment payments made to the Association hereunder. All management contracts entered into by the Association shall provide for cancellation by a majority vote (determined in accordance with Article 4 hereof) of the membership of the Association. It is provided, however, that no cancellation shall be effective until the Association has a contract with a successor Manager which is to become operative immediately upon the cancellation of the pending agreement. It is further provided that the Association shall not employ a successor Manager without having first given thirty (30) days' written notice to all holders of first mortgages on Units who have registered with the Association such holder's name and address. If within said thirty (30) day period, 50% or more of said registered mortgage holders have filed with the Association, at its address to be specified in said notice, their written objection thereto, the proposed change of management shall not be effected.

(f) That the Association's agents and employees shall have the right, after reasonable notice to the Owner, to enter into any Unit or upon any portion of the Common Areas at reasonable hours in connection with performing the maintenance and construction for which the Association is responsible.

6. ASSESSMENTS.

6.1 Purpose of Assessments. The assessments levied by the Association as hereinafter provided shall be used exclusively for the purpose of promoting the health, safety, welfare and recreation of the Members of the Association and, in particular, for the improvement and maintenance in a first-class condition and in a good state of repair of the Project, services and facilities devoted to this purpose, and relating to the use and enjoyment of the Common Areas.

6.2 Common Assessments.

(a) Common Assessments for Common Expenses shall be made by the Board of Directors of the Association for each calendar year not less than thirty (30) days prior, nor more than thirty (30) days subsequent, to the beginning of each such calendar year and at such other and additional times as in the judgment of the Board of Directors additional Common Assessments for Common Expenses are required. The Board of Directors shall commence making the Common Assessments as of the date of close of the first sale of a Condominium in the Project.

(b) The total of each such annual Common Assessment shall be in the amount of the estimated Common Expenses for the first year, including a reasonable allowance for contingencies and reserves.

(c) If the annual Common Assessment is not made as required, a payment in the amount required by the last prior

annual Common Assessment shall be due upon each assessment payment date until changed by a new assessment.

(d) The annual Common Assessment payable by each Owner shall be payable in twelve (12) equal monthly installments on the first day of each calendar month, or at such other date or times and in such other installments as the Association may determine. Installments more than 10 days past due bear interest at the rate of 10% per annum or at the maximum rate allowable on similar debts in the State of Texas.

(e) Each Owner shall pay his proportionate share of the total Common Assessments commencing on the date of the close of the sale of his Condominium. Until the sale of 66 1/2% of the Units in the Project, DECLARANT will subsidize the Association. As to each unsold Unit, DECLARANT shall pay its proportionate share of the total Common Assessments commencing on the date the Deed evidencing the sale of more than 66 2/3 % of the Units is filed for record in the Deed Records of El Paso County, Texas.

6.3 Special Assessments. Special Assessments against particular Owners and their respective Condominiums shall be made by the Board of Directors of the Association for the repair of damage or loss caused by the act or neglect of an Owner causing damage or loss to the Common Areas or to the property of other Owners, upon the date when the cost has been incurred by the Association for the corrective work or corrective action and written demand for payment thereof has been sent by mail to the particular Owner. The amount of the Special Assessment shall be due and payable by the Owner to the Association on the said date of demand, and shall bear interest from the expiration of 10 days following demand at the rate of 10% per annum, or at the maximum rate allowable on similar debts in the State of Texas, whichever is lower.

6.4 Taxes and Governmental Assessments. The assessment of each Condominium for taxes and special assessments by governmental bodies which are or would become a lien on the

Project or any part thereof, when such taxes and special assessments are not separately taxed or assessed to a Condominium, shall be paid by the Association as another item of the Common Expenses. The Association shall assess each Owner on such basis and as part of the Common Assessment.

6.5 Commingling of Assessments. Except where otherwise expressly provided herein, all sums collected by the Association from assessments may be commingled in a single fund, and without the necessity of a specific accounting for each element of Common Expense for which assessment has been made.

6.6 Late Charges. The Association shall also be entitled to collect a late charge in such amounts and upon such conditions as the Board of Directors may from time to time determine.

6.7 Vendor's Lien. In each deed of a Condominium by DECLARANT to an Owner, there shall be expressly reserved a Vendor's Lien ("Vendor's Lien") to secure the payment of all assessments due and to become due pursuant to this Declaration, which Vendor's Lien shall be transferred and assigns therein to the Association. By acceptance of a deed from DECLARANT, each Owner (and his subsequent successors and grantees) assumes and agrees to pay all such assessments, including interest and reasonable collection costs (including attorney's fees), in accordance with the terms and provisions of this Declaration.

The lien so provided shall constitute a lien on such condominium prior to all other liens except only (i) a valid tax lien on the Condominium in favor of any assessing agency and special districts, and (ii) all sums unpaid on the first purchase money lien of record.

The lien so provided may be enforced by sale of the Condominium by the Association, its attorney, or other person authorized to make the sale after failure by the Owner to pay

such assessment in accordance with its terms. The Association shall have the power to bid on the Condominium at foreclosure sale and to hold, lease, mortgage and convey the same. Suit to recover a money judgment for unpaid assessments shall be maintainable without foreclosing or waiving the lien securing the same.

6.8 Subordination of Vendor's Liens. If any Condominium subject to a lien created by any provision of this Declaration shall be subject to the lien of a first purchase money mortgage of record: (i) the foreclosure of any lien created by anything set forth in this Declaration shall not operate to affect or impair the lien of such mortgage; and (ii) the foreclosure of the lien of such mortgage or the acceptance of a deed in lieu of foreclosure shall be subordinate to the lien of the mortgage, with the foreclosure-purchaser and purchasers therefrom or deed-in-lieu grantee and purchasers therefrom taking title free of the lien hereof for all the Common Assessments that have come due up to the time of the foreclosure or deed given in lieu of foreclosure, and until the Unit is sold or leased by the Mortgagee. All Assessments as shall have come due up to foreclosure or the acceptance of a deed in lieu of foreclosure and until the Unit is sold or leased by the Mortgagee which have not been paid shall be deemed to be Common Expenses collectible from all of the Units, including the Units acquired on a foreclosure sale or as the result of the acceptance of the deed in lieu of foreclosure, in the manner provided herein.

6.9 Assessment Roll. The assessments against all Owners shall be set forth upon a roll of the Units which shall be available in the office of the Association for inspection at all reasonable times by Owners or their duly authorized representatives. Such roll shall indicate for each Unit the name and address of the Owner or Owners, the assessments for all purposes and the amounts of all assessments paid and unpaid. A certificate made by the Manager or the Board of Directors of the Association as to the status of an Owner's assessment account shall

limit the liability of any person for whom made other than the Owner. The Association shall issue such certificates to such persons as an Owner may request in writing.

6.10. Liability for Assessments. The Owner of a Unit shall be personally liable for any and all Assessments made by the Board of Directors of the Association in accordance with the provisions hereof. In a voluntary conveyance of a Condominium, the grantee of the Condominium shall be jointly and severally liable with the grantor for all unpaid assessments by the Association against the latter up to the time of the grant or conveyance, without prejudice to the grantee's right to recover from the grantor the amounts paid by the grantee therefor. However, any such grantee shall be entitled to a statement from the Manager or the Board of Directors of the Association, setting forth the amount of the unpaid assessments against the grantor due the Association and such grantee shall not be liable for, nor shall the Condominium conveyed by subject to a lien for, any unpaid assessments made by the Association against the grantor in excess of the amount therein set forth. Notwithstanding the foregoing, a purchaser (other than the Mortgagee) of a Condominium at any judicial or trustee sale shall be liable only for assessments that come due after such sale and for that portion of assessments already due prorated to the period after the date of such sale.

Amendments to this Article 6 shall only be effective upon written consent of the Owners and their first mortgagees, if any, of 75% of the Units, whether such amendment is attempted by way of modification of the Association Articles of Incorporation or By-Laws.

6.11. No Exemptions. No Owner may exempt himself from liability for assessments duly levied by the Association, nor release the Condominium owned by him from the liens and charges hereof, by waiver of the use and enjoyment of the Common Areas and the facilities thereon.

7. INSURANCE.

The insurance, other than title insurance, which shall be carried upon the Property shall be governed by the following provisions:

7.1 Authority to Purchase. All insurance provided for in this Article 7 (except where otherwise specifically provided) or otherwise deemed prudent by the Association shall be purchased by the Association and the premiums thereon shall be a Common Expense to be paid by Common Assessments.

To assist in the purchase and administration of such policies of insurance as may be required hereunder or deemed prudent by the Association in the conduct of its business, the Association may employ the services of an independent insurance analyst, consultant, or broker, the expense of which shall be a Common Expense.

7.2 Property Insurance. Each Unit, but not including the personal property and furnishings contained within nor any improvements added by an Owner, shall be insured (to the extent deemed practical and prudent) so as to provide for and assure full replacement thereof in the event of damage or destruction from the perils specified below. In addition, the Common Areas and all improvements thereon and all personal property as may be owned separately by one or more of the Owners, shall be insured (to the extent deemed practical and prudent) so as to provide for and assure full replacement thereof in the event of damage or destruction from said perils.

All such policies shall be issued in the name of the Association and may contain a loss payable endorsement in favor of the Association which shall be subordinate in position only to a loss payable indorsement in favor of a lender holding a first mortgage lien against a Condominium.

Such policies shall provide that losses thereunder shall be adjusted with and payable to the Association for the exclusive account of the Association.

Such coverage as is required under this subsection shall afford protection against:

(a) Loss or damage by fire and other hazards covered by the standard extended coverage and vandalism and malicious mischief endorsements;

(b) Such other additional hazards covered by standard extended coverage endorsement as may from time to time become available;

(c) Additional perils shall be at the option of the Association.

The Association may comply with the above requirements by the purchase of blanket coverage and may elect such deductible provisions which in the opinion of the Association are (i) consistent with good business practice and (ii) in accordance with the requirements of any mortgagee owing a first mortgage lien against a Condominium.

Insurance proceeds shall not be commingled with other association funds and shall be used forthwith exclusively for the restoration of the damaged or destroyed Units and the damaged or destroyed portions of the Common Areas and the improvements and/or personal property thereon.

7.3 Public Liability and Property Damage. The Association shall purchase broad form Comprehensive Liability coverage in such amounts and in such forms deemed appropriate by it. This coverage shall be issued in the name of the Association and shall include Owners in their capacity as Members of the Association as additional insureds. Coverage under this policy shall include, but not be limited to, legal liability of the Association for bodily and personal injuries, property damages, operations of automobiles on behalf of the Association and operations of the Association in connection with the operation, maintenance or use of the Common Areas.

7.4 Workmen's Compensation. The Association shall purchase Workmen's Compensation Insurance in such form as to

meet the requirements of law for injuries to Association employees.

7.5 Crime. The Association may purchase coverage for dishonesty of employees, destruction or disappearance of money or securities and against forgery in amounts and in such forms as shall be required by the Association.

7.6 Other Insurance. The Association may purchase such other forms of insurance as may benefit the Owners or the Project, in such amounts as the Board of Directors may deem proper; and such additional coverage may include directors' liability coverage for the Board of Directors of the Association.

7.7 Owner Insurance. Each Owner, and not the Association shall have the responsibility of obtaining and keeping in full force and effect, at his sole expense, standard fire and extended coverage insurance on the personal property and furnishings contained in his Unit or located on the Common Areas, and on any improvements added to his Unit by an Owner, and such other insurance as he may elect to purchase in addition to the insurance purchased by the Association, provided, however, that in no event is the insurance coverage purchased by the Association to be brought into contribution with insurance purchased by any Owner.

7.8 Waiver of Subrogation. Insofar as, and to the extent that, it shall be possible to obtain insurance coverage from responsible companies with such a clause, the Association shall, in the case of the insurance coverage it purchases on the Project, and each Owner shall, in the case of the insurance coverage he purchases on his unit, obtain insurance coverage which provides that their respective insurance companies shall have no right of subrogation against, as the case may be, the Association and its employees, Owners and members of their respective households. Accordingly, to the extent the respective parties shall actually collect such insurance, carriers shall have no right of subrogation against the other(s).

8. MAINTENANCE OF PROJECT.

8.1 Duties of Association. The Association shall have the responsibility of maintaining, repairing, replacing, and otherwise keeping in a first-class condition all portions of the Project not required in this Article to be maintained by the Owners.

8.1.1 Access to Units. The Association's agents and employees shall have the right to enter each Unit from time to time during reasonable hours as may be necessary for the maintenance, repair or replacement of any of the Common Areas therein or accessible therefrom; provided, however, that such right of access shall be immediate for making emergency repairs therein in order to prevent damage to the Common Areas or to another Unit. If requested by the Association, each Owner shall furnish to the Association a duplicate key to the entrance door to his Unit and shall furnish a new duplicate key upon any change of locks thereto.

8.1.2 Damage to Units. Damage to the interior or any part of a Unit resulting from the maintenance, repair, emergency repair or replacement of any of the Common Areas or as a result of emergency repairs within another Unit shall be a Common Expense; provided, however, that if such damage is caused by the negligent or tortious acts of an Owner, member of his family, his agent, employees, invitees, licensees or tenants, then such Owner shall be responsible and liable for all of such damage, which shall be considered a Special Expense.

8.1.3 Duties of Owners. An Owner shall be obligated to repair, replace and maintain in good repair and condition (a) the Fixtures (as hereinafter defined) within his Unit; (b) the finished interior surfaces of the perimeter walls, ceilings,

floor, doors and windows within his unit, including, but not limited to, such materials as paneling, wallpaper, paint, wall and floor tile and flooring (but not including, the sub-flooring); (c) the balconies and/or terraces of his Unit to the exterior surfaces of same; (d) his Air Conditioning/heating equipment; and (e) his Patio Area. An Owner shall also have the responsibility of replacing all broken windows and repairing and replacing (and painting the exterior surfaces of) all doors in the perimeter walls of his Unit. Provided, however, the repair, replacement and maintenance required by this Section of those areas which are exposed to public view shall be done in a manner consistent with the decor of the Project and shall be subject to the control and direction of the Association. No Owner shall disturb or relocate any Utilities (as hereinafter defined) running through his Unit nor shall any Owner do any act which will impair the structural soundness of the Building or impair any easement herein granted or reserved.

8.2.1 Definition of Utilities. By the term "Utilities" as used in this Article is meant the lines, pipes, ducting, wires, conduits or systems located within the walls of a Building, which are a part of the Common Areas.

8.2.2 Definition of Fixtures. By the term "Fixtures" as used in this Article is meant the fixtures and equipment within a Unit commencing at the point where they connect with the Utilities.

9. RECONSTRUCTION OR REPAIR OF IMPROVEMENTS.

9.1 When Reconstruction Required. If less than two-thirds (2/3) of all Buildings and the other Common Areas improvements in the Project shall be damaged or destroyed by fire or other casualty, then the Project shall be repaired or reconstructed. If more than two-thirds (2/3) of such improvements shall be damaged or destroyed, then reconstruction or repair shall be effected only with the unanimous consent of all Owners. The extent of damage shall be determined solely by the Board of

Directors, and its decision in this regard shall be final and conclusive.

9.2. Restoration of Common Areas. When reconstruction or repair of the Common Areas shall be required, the same shall be accomplished by the Association, and each Owner does hereby irrevocably name, constitute and appoint the Association as his true and lawful attorney-in-fact for the purpose of accomplishing such reconstruction or repair, hereby granting to such Association, acting by and through its duly authorized officers and agents, full and complete authorization, right and power to make, execute and deliver, in his name, place and stead, any contract and any other instrument with respect to the interest of such Owner which is necessary and appropriate to accomplish the powers herein granted. Such reconstruction or repair shall be substantially in accordance with this Declaration and the original plans and specifications of the Project unless the Owners shall unanimously decide otherwise.

9.3. Repair of Units. Each Owner shall be responsible for the reconstruction, repair or replacement of the interior of his Unit, including, but not limited to, the floor coverings, wall coverings, window shades, draperies, interior walls, furniture, furnishings, decorative light fixtures, and all appliances located therein. Each Owner shall also be responsible for the costs, not otherwise covered by insurance carried by the Association, of any reconstruction, repair or replacement of any portion of this Project necessitated by his negligence or misuse or the negligence or misuse of his guests, agents, employees or contractors, which shall be considered a Special Expense. In the event damage to all or any part of the interior of a Unit is covered by insurance held by the Association for the benefit of such Owner, then such Owner shall begin reconstruction, repair or replacement of his Unit upon receipt of the insurance proceeds, or any portion thereof, from the Association. In the event such damage is not covered by insurance held by the Association for the benefit of such Owner, then such Owner

BODX 910 PAGE 1880

shall begin reconstruction, repair or replacement of his Unit within sixty (60) days after the date of such damage. All reconstruction, repair or replacement of the interior of a Unit required under this paragraph shall be subject to the control and supervision of the Association during the course thereof.

9.4 Cost of Repairs.

9.4.1 Estimate of Repairs. As soon as possible after the occurrence of a casualty which causes damage to any part of the Project for which the Association has insurance coverage, (hereinafter referred to as the "Casualty") the Association shall obtain reliable and detailed cost estimates of (i) the cost of restoring all damage caused by the Casualty to the Common Areas (hereinafter referred to as the "Common Areas Costs") and (ii) the cost of restoring that part of the damage caused by the Casualty to each Unit which is or would be covered by insurance held by the Association without regard to the Policy limits of such insurance (hereinafter referred to as the "Unit Costs").

9.4.2 Application of Insurance Proceeds. All insurance proceeds available to the Association with respect to the Casualty shall first be applied to the payment of actual Common Area Costs and the balance thereof, if any, shall thereafter be applied to the payment of the actual Unit Costs. However, if such insurance proceeds are not sufficient to cover such estimated costs, then an assessment shall be made against the Owners by the Association in the following manner:

(i) All owners shall be assessed on the basis of their percentage of ownership in the Common Areas for the payment of the estimated Common Area Costs not otherwise paid for by insurance held by the Association, which shall be considered Common Expenses.

(ii) Each Owner of a damaged Unit shall be assessed an amount equal to the difference between his estimated Unit Costs and a sum calculated by multiplying the amount, if any, of the remaining insurance proceeds held by the Association with respect to the Casualty by a fraction, the numerator of which is his estimated Unit Costs and the denominator of which is the total of all of the estimated Unit Costs, which shall be considered Special Expenses.

9.5 Eminent Domain. In the event of a taking by eminent domain of part or all of the Common Areas, the award for such taking shall be payable to the Association, which shall represent the Owners named in the condemnation proceedings. Said award shall be utilized to the extent possible for the repair, restoration, replacement and/or improvement of the remaining Common Areas. Any funds not so utilized shall be applied in payment of Common Expenses otherwise assessable to the Members of the Association. In the event of a taking by eminent domain of all or a part of a Unit, the award made for such taking shall be payable to the Owner and his Mortgagee, if any, as their interests may appear.

10. RESTRICTIVE COVENANTS.

10.1 Residential Use. Each Unit shall be occupied and used by its Owner only as a private dwelling for the Owner, his family, tenants and social guests, and for no other purpose.

10.2 Occupants. Owner agrees that all permanent occupants residing at the herein described "Unit" must be fourteen (14) years of age or older. Any guests of said occupants who are under the age of fourteen (14) may not reside at the herein described "Unit" for more than sixty (60) days.

10.3 Alterations. No Owner shall make structural alterations or modifications to his Unit or to any of the Common Areas including, but not limited to, the erection of antennas, aerials, awnings, the placement of any reflective or other material in the windows of his Unit or other exterior attachments without the written approval of the Association. The Association shall not approve any alterations, decorations or modifications which would jeopardize or impair the soundness, safety or appearance of the Project.

10.4 Temporary Structures. No structures of a temporary character, trailer, tent, shack, or other out-building shall be used or permitted to be kept or stored by an Owner on any portion of the Common Areas or within his Unit in such a manner as to be exposed to public view, at any time either temporarily or permanently.

10.5 Improper Activities. No immoral, improper, unlawful or offensive activities shall be carried on in any Unit or upon the Common Areas, nor shall anything be done which may be or become an annoyance or nuisance to the Owners. No Owner shall store any dangerous explosives or inflammable materials either in his Unit or upon the Common Areas, or permit anything to be done or keep or permit to be kept in his Unit or on the Common Areas anything that will increase the rate of insurance on the Project.

10.6 Signs. No signs or other advertising devices shall be displayed which are visible from the exterior of any Unit or on the Common Areas, including "For Sale" signs, except in conformity with the Rules and Regulations promulgated by the Board of Directors.

10.7 Use of Common Areas. The Common Areas, except for Limited Common Areas, shall not be used for storage of supplies or personal property. The Common Areas shall not be used for storage of trash or refuge of any kind except in common trash receptacles placed at the discretion of the Association, nor shall the Common Areas be used in any way for the drying, shaking or airing of clothing or other fabrics. Stairs, elevated walkways, entrances, sidewalks, yards, driveways and parking areas shall not be obstructed in any way nor shall unauthorized persons use them for other than their intended purposes. In general, no activities shall be carried on nor condition maintained by any Owner either in his Unit or upon the Common Areas which despoils the appearance of the Project.

10.8 Pets. No animals shall be kept in the Project except household pets. Such pets may not be kept or bred for any commercial purpose and shall have such care and restraint so as not to be obnoxious or offensive on account of noise, odor, or unsanitary conditions. No savage or dangerous animals shall be kept. No more than one household pet may be kept in any Unit without written permission of the Association. No pets shall be permitted to run loose upon the Common Areas, except for Limited Common Areas, and any Owner who causes any animal to be brought upon the Project shall indemnify and hold harmless the Association for any loss,

damage or liability which the Association may sustain as a result of the presence of such animal on the premises, whether or not the Association has given its permission therefor.

10.7 Limitation During Sales Period. None of the restrictions contained in this Article 11 shall apply to the commercial activities, signs, billboards, if any, of the DECLARANT during the sales period of the Condominiums or to the activities of the Association in furtherance of its powers and purpose set forth herein and in its Articles of Incorporation and By-Laws as the same may be amended from time to time.

11. DEFAULT.

11.1 Definition. Failure to comply with any of the terms of this Declaration, the Articles of Incorporation or By-Laws of the Association, or the duly adopted Rules and Regulations of the Association, shall constitute an event of default and shall be grounds for relief, which may include without limitation an action to recover sums due for damages and injunctive relief, or any combination thereof.

11.2 Remedies. In addition to all other remedies herein contained or as may be provided by law, the Association may discontinue the furnishing of any utilities or other services to an Owner who is in default of his obligations to the Association or other Owners as set forth herein upon thirty (30) days written notice to such Owner and to any Mortgagee of such Owner's Unit of its intent to do so.

11.3 Costs. In any proceeding arising because of any alleged default by an Owner, the Association, if successful, shall be entitled to recover the costs of the proceedings and reasonable attorneys' fees from such Owner.

11.4 No Waiver. The failure of the Association or of any Owner to enforce any right, provision, covenant or condition which may be granted by the Act, this Declaration, the Articles of Incorporation or By-Laws of the Association, or the Rules

and Regulations, shall not constitute a waiver of the right of the Association or of any such Owner to enforce such right, provision, covenant or condition in the future.

11.5 Rights Cumulative. All rights, remedies and privileges granted to the Association or any Owner pursuant to the provisions of the Act, this Declaration, the Articles of Incorporation or By-Laws of the Association, or the Rules and Regulations, shall be deemed to be cumulative and the exercise of any one or more of such rights, remedies and privileges shall not be deemed to constitute an election of remedies, nor shall it preclude the party thus exercising the same from exercising such other additional rights, remedies or privileges, as may be available to such party at law or in equity.

12. GENERAL PROVISIONS.

12.1 The Project shall not be abandoned or terminated without the written consent of at least 75% of the Owners of the Units and all of the lenders holding first mortgage liens on Units of the Project and who have registered their names and addresses with the Association; except such consent is not required for abandonment and termination provided by law in the case of a taking by condemnation. A lender shall be deemed to have given its consent if it has not replied within thirty (30) days after receipt of written notice of the Owners' desire to abandon or terminate the Project.

12.2 No Unit in the Project may be partitioned or subdivided without the prior written approval of the Association and the holder of any first mortgage lien on such Unit.

12.3 Any holder of a first lien mortgage on any Unit in the Project, upon request, shall be entitled to inspect the books and records of the Association during normal business hours.

12.4 In the event of substantial damage to or destruction of any Unit, or to any material part of the Common Areas, any holder of a first mortgage lien who has registered its name and

address with the Association shall be entitled to timely written notice of such damage or destruction.

12.5 If any Unit or portion thereof, or the Common Areas or any portion thereof, is made the subject of any condemnation or eminent domain proceeding, or is otherwise sought to be acquired by any lawful condemning authority, then any holder of a first mortgage lien on any Unit in the Project who has registered its name and address with the Association shall be entitled to timely written notice of any such proceeding or proposed acquisition.

12.6 Acceptance of Governing Rules. The Association, all present or future Owners, tenants or future tenants, or any other persons using the facilities of the Project are subject to and shall comply with the Act, this Declaration, the Articles of Incorporation and By-Laws of the Association, and the Rules and Regulations, and the acquisition, occupancy or rental of a Unit shall signify that all such documents are accepted and ratified. In the event of a conflict in any of the provisions of any such documents, the documents shall govern or control in the following order or preference: (i) the Act; (ii) this Declaration; (iii) the Articles of Incorporation of the Association; (iv) the By-Laws of the Association; and (v) the Rules and Regulations.

12.7 Delivery of Notices. All notices or other documents required herein to be delivered by the Association to Owners may be delivered either personally or by mail. If delivered personally, same shall be deemed to have been delivered when actually received by the Owner or when left at the front door of his Unit. If mailed, same shall be deemed delivered when deposited in the United States Mail addressed to the Owner at his address as it appears on the records of the Association, with postage thereon prepaid.

12.8 Severability. If any of the provisions of this Declaration or any paragraph, sentence, clause, phrase or word,

or the application thereof in any circumstance be invalidated, such invalidity shall not affect the validity of the remainder of this Declaration, and the application of any provisions, paragraph, sentence, clause, phrase or word in any other circumstances shall not be affected thereby.

12.9 Paragraph Titles. Paragraph titles used in this Declaration are for convenience of reference and are not intended to limit, enlarge or change the meaning of the contents of the various paragraphs.

IN WITNESS WHEREOF, DECLARANT has duly executed this Declaration on the day and year first hereinabove written.

SIERRA PROPERTIES, INC.

Attest and Seal
not Required

By Charles C. Wood
President

STATE OF TEXAS)
)
COUNTY OF EL PASO)

BEFORE ME, the undersigned authority, on this day personally appeared Charles C. Wood, President of Sierra Properties, Incorporated, a corporation, known to me to be the person whose name is subscribed to the foregoing instrument and acknowledged to me that he executed the same for the purposes and consideration therein expressed, in the capacity therein stated, and as the act and deed of said corporation.

GIVEN UNDER MY HAND AND SEAL OF OFFICE on this
5th day of October, 1978.

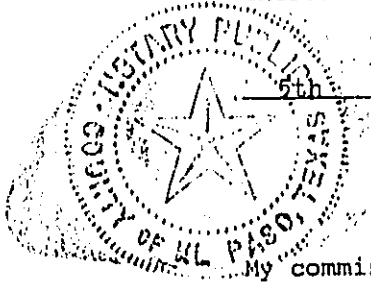

Julie Hawkins
Notary Public in and for
El Paso County, Texas

My commission expires:
August 7, 1980

PREPARED FOR: Sierra Properties, Inc.

CAMELOT TOWNHOMES TRACT

PROPERTY DESCRIPTION

Description of a Tract of land being a portion of Lot 8, Camelot Heights Subdivision and a portion of F.W. Brown Survey No. 224 containing 3.161 acres in El Paso County, Texas and being more particularly described by metes and bounds as follows:

Beginning at the northwesterly corner of said Lot 8, Camelot Heights; thence, South $82^{\circ}56'$ East a distance of 287.06 feet to the northwesterly corner and POINT OF BEGINNING of said Camelot Townhomes Tract;

Thence, along the perimeter the following courses: South $82^{\circ}56'00''$ East a distance of 63.75 feet to the centerline of a sidewalk;

Thence, along the said sidewalk centerline the following courses: South $46^{\circ}11'30''$ West a distance of 33.16 feet to an angle point; South $12^{\circ}59'14''$ West a distance of 9.04 feet to an angle point; leaving said sidewalk centerline and continuing along the said perimeter South $77^{\circ}00'46''$ East a distance of 50.02 feet to an angle point; South $10^{\circ}27'00''$ West a distance of 57.06 feet to an angle point; South $13^{\circ}30'00''$ West a distance of 113.40 feet to an angle point; South $06^{\circ}46'00''$ East a distance of 34.29 feet to an angle point; South $74^{\circ}10'00''$ East a distance of 40.00 feet to an angle point; North $76^{\circ}28'30''$ East a distance of 40.93 feet to an angle point; North $56^{\circ}30'00''$ East a distance of 248.00 feet to an angle point; North $66^{\circ}30'00''$ East a distance of 144.00 feet to an angle point; S $82^{\circ}56'00''$ East a distance of 125.96 feet to the northeasterly corner of the said Tract;

Thence, along the centerline of a sidewalk the following courses: South $14^{\circ}25'06''$ West a distance of 20.79 feet to an angle point; South $19^{\circ}29'42''$ West a distance of 22.28 feet to an angle point; South $39^{\circ}46'56''$ West a distance of 27.63 feet to an angle point; South $59^{\circ}00'40''$ West a distance of 126.92 feet to an angle point;

Thence, leaving said sidewalk centerline and continuing with the perimeter the following courses: South $30^{\circ}23'27''$ East a distance of 20.81 feet to an angle point; South $58^{\circ}03'30''$ West a distance of 345.13 feet to the southeasterly corner of the said Tract; South $79^{\circ}10'00''$ West a distance of 110.60 feet to an angle point; North $74^{\circ}46'00''$ West a distance of 112.28 feet to the southwesterly corner of the said Tract;

Thence, continuing along the said perimeter description the following courses: North $36^{\circ}25'36''$ West a distance of 129.70 feet to an angle point; North $04^{\circ}23'53''$ East a distance of 99.28 feet to an angle point; North $30^{\circ}35'40''$ East a distance of 220.77 feet to the POINT OF BEGINNING of the said Camelot Townhomes Tract containing 3.161 acres, more or less.

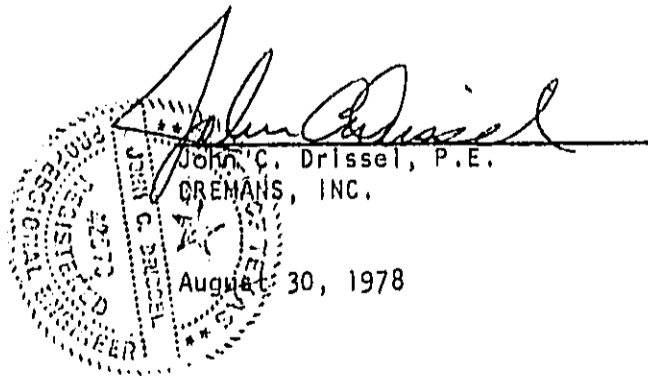

EXHIBIT "A"

BCCX 010 PAGE 1888



The State of Texas
Secretary of State

CERTIFICATE OF INCORPORATION

12

CAMELOT FURNITURE ASSOCIATION, INC.
CHAPTER NUMBER 423947

THE UNDERSIGNED, AS SECRETARY OF STATE OF THE STATE OF TEXAS,
HEREBY CERTIFIES THAT DUPLICATE ORIGINALS OF ARTICLES OF INCORPORATION
FOR THE ABOVE CORPORATION, ONLY SIGNED AND VERIFIED, HAVE BEEN RECEIVED
IN THIS OFFICE AND ARE FOUND TO CONFORM TO LAW.

ACCORDINGLY THE UNDERSIGNED, AS SUCH SECRETARY OF STATE, AND BY
VIRTUE OF THE AUTHORITY VESTED IN HIM BY LAW, HEREBY ISSUES THIS
CERTIFICATE OF INCORPORATION AND ATTACHES HERETO A DUPLICATE ORIGINAL
OF THE ARTICLES OF INCORPORATION.

DATED AUG. 7. 1971





Secretary of State
RSC

EXHIBIT B

BOOK 940 PAGE 1889

FILED
In the Office of the
Secretary of State of Texas

ARTICLES OF INCORPORATION
OF
CAMELOT TOWNHOMES ASSOCIATION, INC.

AUG 7 1978

Patrick Brice

Attorney, Corporation Division

We, the undersigned natural persons over the age of twenty-one years and citizens of the State of Texas, acting as incorporators of a corporation under the Texas Nonprofit Corporation Act, do hereby adopt the following Articles of Incorporation for such corporation:

ARTICLE ONE

The name of the corporation is CAMELOT TOWNHOMES ASSOCIATION, INC.

ARTICLE TWO

The corporation is a nonprofit corporation, no part of the income of which is distributable to any members, directors, trustees or officers and no part of the net earnings of which shall inure to the benefit of any private individual.

ARTICLE THREE

The period of its duration is perpetual.

ARTICLE FOUR

The purposes for which the corporation is organized are:

1. To provide a means of administering, preserving and maintaining a condominium project to be known as Camelot Townhomes, all in accordance with the terms and provisions of the Condominium Act of the State of Texas, Article 1301a, Vernon's Annotated Texas Statutes, and the Condominium Declaration for the project filed or to be filed pursuant to the Act in the Condominium Records of El Paso County, Texas;

2. Subject to part 4 of the Texas Miscellaneous Laws Act, to exercise all powers of a nonprofit corporation as set forth in the Texas Nonprofit Corporation Act and to do all other things necessary and proper to accomplish the purposes set out

herein and to administer and enforce the provisions of the Condominium Act and the Declaration for said project.

ARTICLE FIVE

The street address of the initial registered office of the corporation is 330 Eubank Drive, El Paso, Texas 79902, and the name of the initial registered agent of the corporation at such address is Charles C. Wood.

ARTICLE SIX

The number of directors constituting the initial Board of Directors of the Corporation is three and the names and address of the persons who are to serve as the initial directors are:

<u>Name:</u>	<u>Address:</u>
Charles C. Wood	330 Eubank Drive El Paso, Texas 79902
William J. Mounce	425 Camino Real El Paso, Texas 79922
James Sorenson	330 Eubank Drive El Paso, Texas 79902

ARTICLE SEVEN

The names and addresses of the incorporators are:

<u>Name:</u>	<u>Address:</u>
Charles C. Wood	330 Eubank Drive El Paso, Texas 79902
William J. Mounce	425 Camino Real El Paso, Texas 79922
James Sorenson	330 Eubank Drive El Paso, Texas 79902

IN WITNESS WHEREOF, we have hereunto set our hands this
the 31st day of July, 1978.

CHARLES C. WOOD

WILLIAM J. MOUNCE

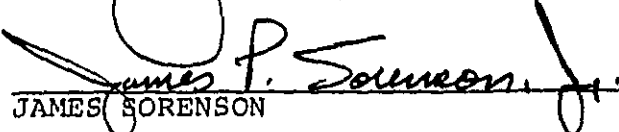

JAMES SORENSON

STATE OF TEXAS)
COUNTY OF EL PASO)

I, Julie Covar, a Notary Public do hereby certify that on this the 31st day of July, 1978 personally appeared before me Charles C. Wood, who being by me duly sworn declared to me that he is the person who signed the foregoing documents as an incorporator and that the statements therein contained are true.

My Commission Expires: 7/31/78

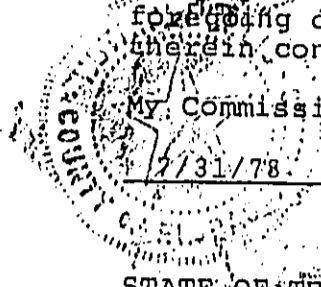
Julie Covar
Notary Public, El Paso County, Texas



STATE OF TEXAS)
COUNTY OF EL PASO)

I, Leslie Thornberry, a Notary Public do hereby certify that on this the 1st day of August, 1978 personally appeared before me William J. Mounce, who being by me duly sworn declared to me that he is the person who signed the foregoing documents as an incorporator and that the statements therein contained are true.

My Commission Expires: 4/30/79

Leslie Thornberry
Notary Public, El Paso County, Texas
LESLIE THORNBERRY
Notary Public, El Paso County, Texas
My commission expires: April 30, 1979

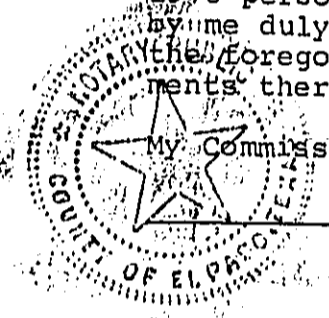

STATE OF TEXAS)
COUNTY OF EL PASO)

I, Julie Covar, a Notary Public do hereby certify that on this the 31st day of July, 1978 personally appeared before me James Sorenson, who being by me duly sworn declared to me that he is the person who signed the foregoing documents as an incorporator and that the statements therein contained are true.

My Commission Expires: 7/31/78

Julie Covar
Notary Public, El Paso County, Texas

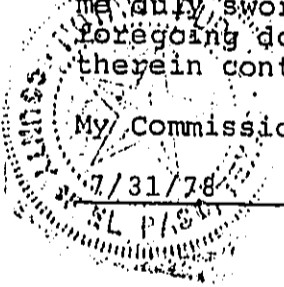

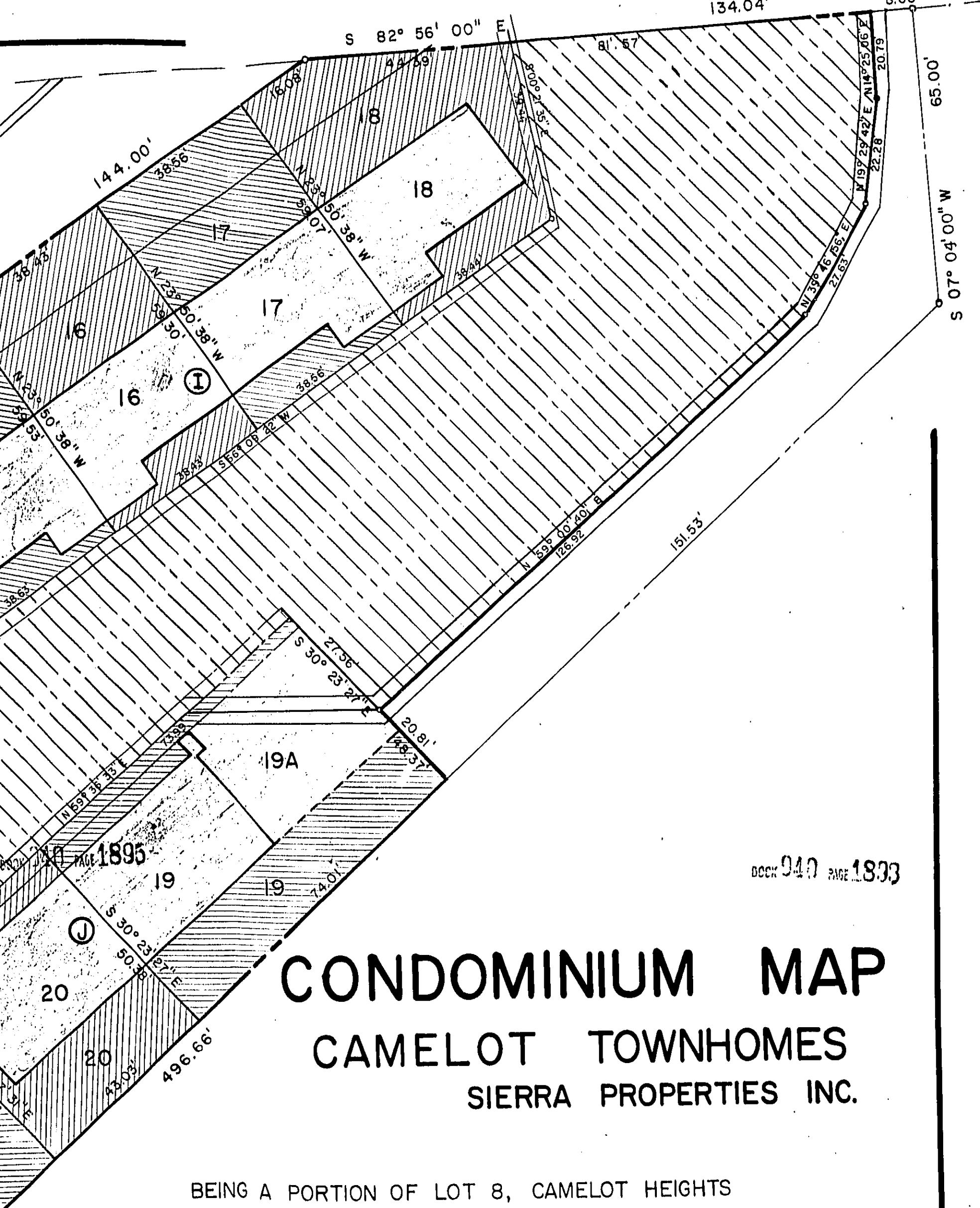

BOOK 940 PAGE 1833

CONDOMINIUM MAP

CAMELOT TOWNHOMES

SIERRA PROPERTIES INC.

BEING A PORTION OF LOT 8, CAMELOT HEIGHTS
 SUBDIVISION AND A PORTION OF F.W. BROWN SURVEY
 NO. 224, EL PASO COUNTY, TEXAS CONTAINING 3.161 ACRES ±

UNIT SIZE LEGEND

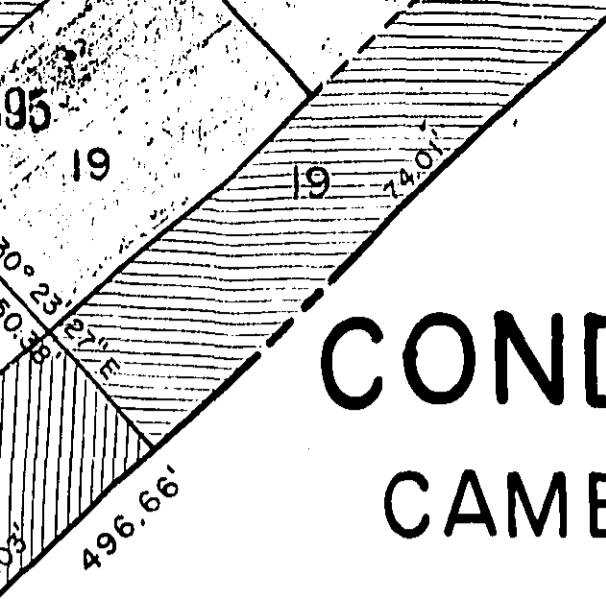

CONDOMINIUM MAP

CAMELOT TOWNHOMES

SIERRA PROPERTIES INC.

BEING A PORTION OF LOT 8, CAMELOT HEIGHTS
SUBDIVISION AND A PORTION OF F.W. BROWN SURVEY
NO. 224, EL PASO COUNTY, TEXAS CONTAINING 3.161 ACRES ±

UNIT SIZE LEGEND

(APPROX. INTERIOR DIMENSIONS ONLY)

UNITS 1 THRU 18 (TYP)
APPROX. INTERIOR AREA: 2000 SQ.FT.
EACH UNIT IS THREE (3) STORY

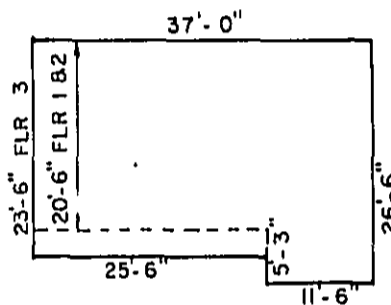

UNITS 19 THRU 33 (TYP).....
APPROX. INTERIOR AREA: 1550 SQ.FT.
EACH UNIT IS TWO (2) STORY

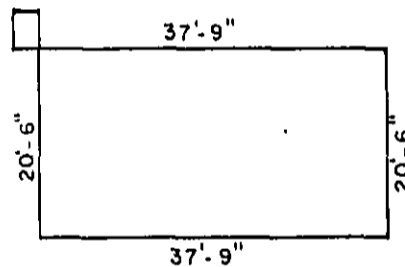

CONDOMINIUM AREA (UNITS)



COMMON AREA



LIMITED COMMON AREA

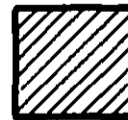
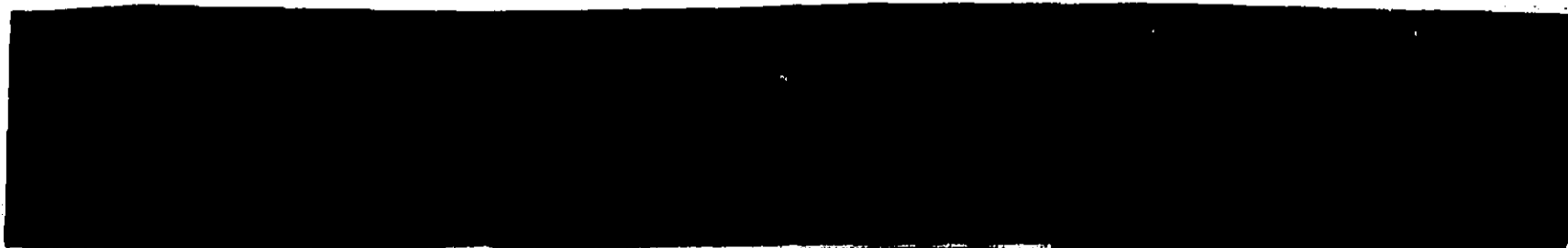
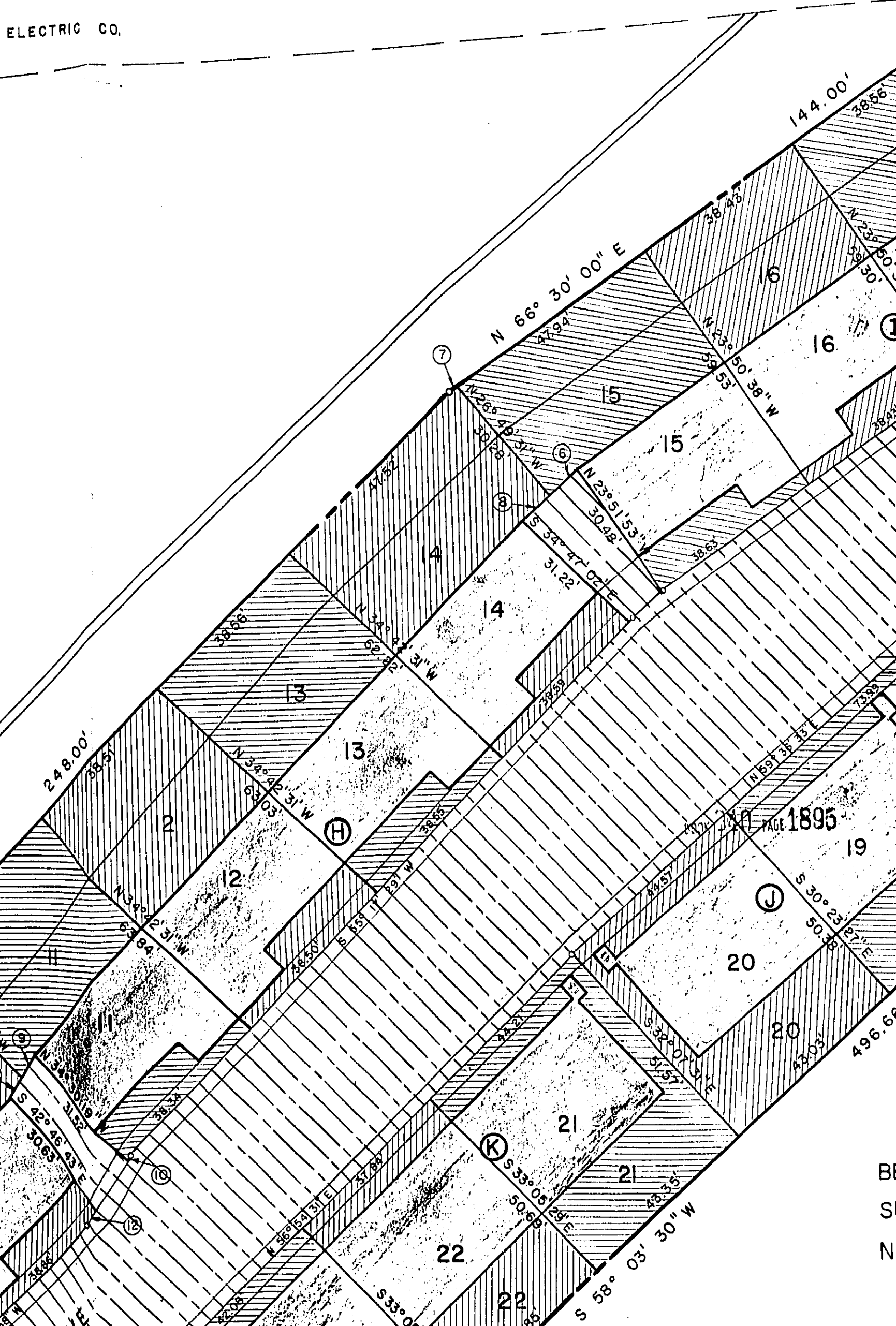

EXHIBIT C

EXHIBIT C



ELECTRIC CO.



PAGE 1895

BL
S
N

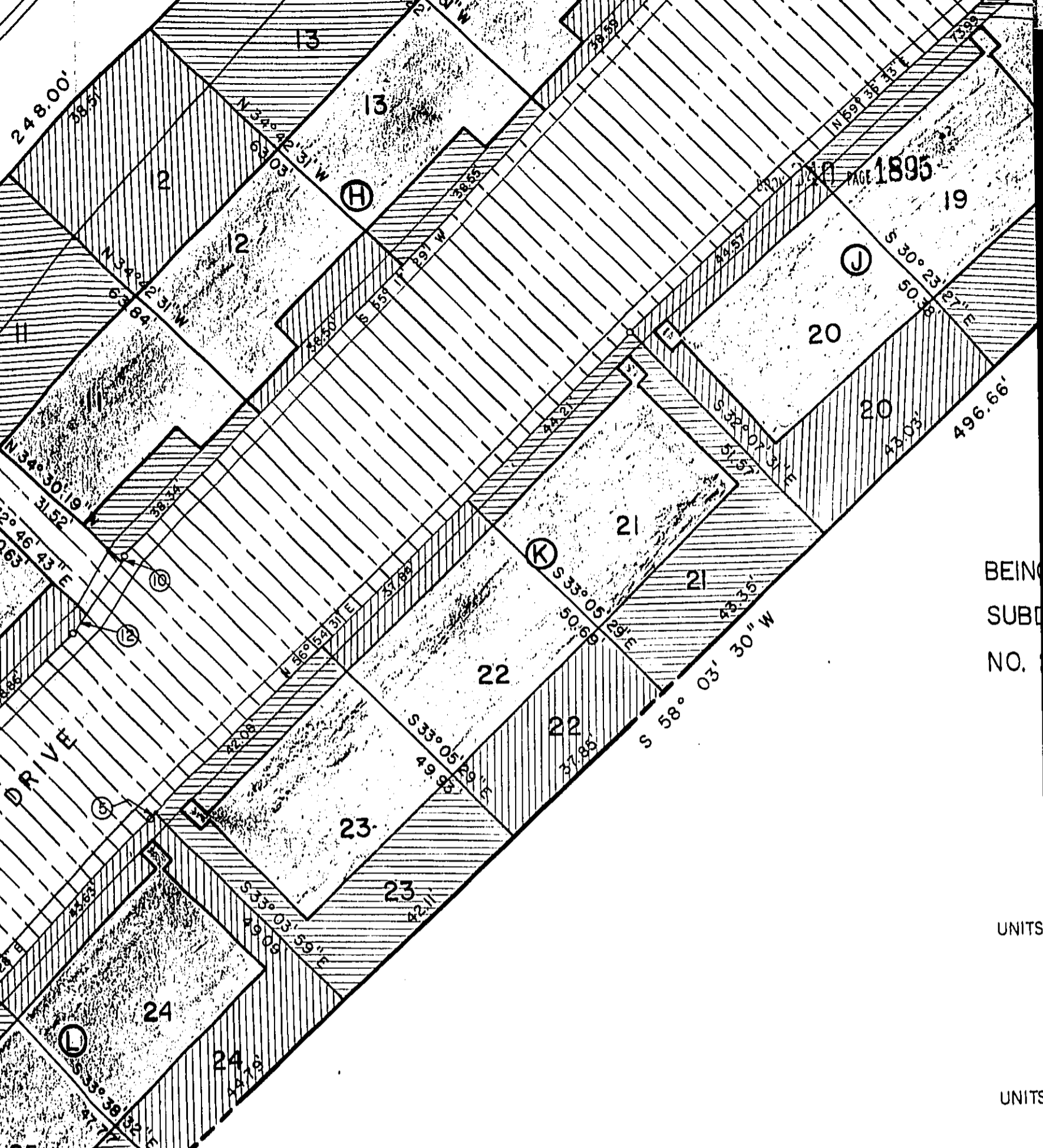

PAGE 1895

BEING
SUBD
NO.

UNITS

UNITS

CON

CON

LIM

NOTE: THE ACTUAL BOUNDARIES OF A UNIT SHALL BE THE INTERIOR SURFACES OF ITS PERIMETER WALLS, FLOORS, CEILINGS, WINDOWS AND DOORS.

CERTIFICATION

I hereby certify that the foregoing Improvement Survey was made by and under the supervision of John C. Drissel, Registered Professional Engineer, No. 42073 and that there are no encroachments except as hereon shown.

BOOK 940 PAGE 1896

John C. Drissel
John C. Drissel, P.E.
CREMANS, INC.

ns
Engineers & Planners
El Paso, Texas

REVISED 10/9/78

SOUTHERN BOUNDARY OF EL PASO ELECTRIC EASEMENT (150' WIDE).

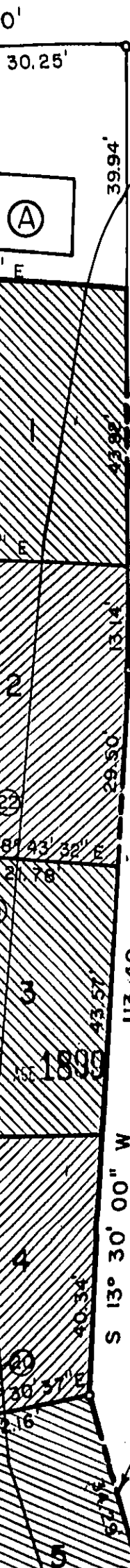

LINE	BEARING	DISTANCE
1.	S36°34'29\"E	3.66'
2.	S75°30'49\"E	0.21'
3.	N77°31'11\"E	4.73'
4.	N56°21'28\"E	2.80'
5.	N56°54'31\"E	1.64'
6.	S59°35'31\"W	7.77'
7.	N66°30'00\"E	3.00'
8.	S59°35'31\"W	7.77'
9.	S41°53'40\"W	5.48'
10.	S43°09'55\"W	0.18'
11.	S41°53'40\"W	5.48'
12.	S43°09'55\"W	5.45'
13.	S67°02'38\"W	0.21'
14.	N76°01'13\"W	5.54'
15.	N82°52'10\"W	0.33'
16.	N76°01'13\"W	5.54'
17.	N35°26'29\"E	5.55'
18.	S74°10'00\"E	3.19'
19.	S16°04'14\"W	2.44'
20.	N35°26'29\"E	5.55'
21.	N15°52'17\"E	4.80'
22.	N15°52'17\"E	4.80'

CAMELOT TOWNHOMES TRACT 3.161 ACRS APPX 340 PAGE 1897
 COMMON AREA 1.231 Ac.

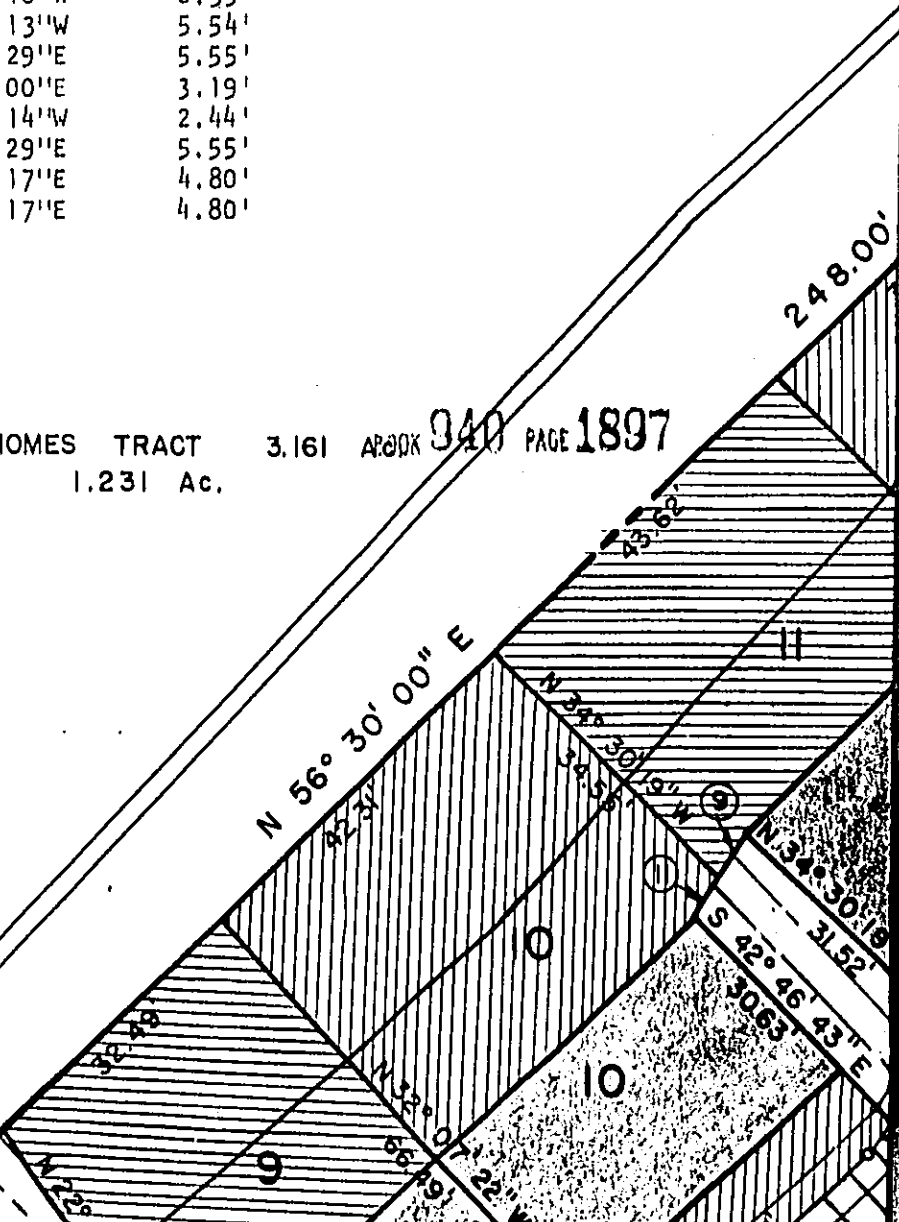
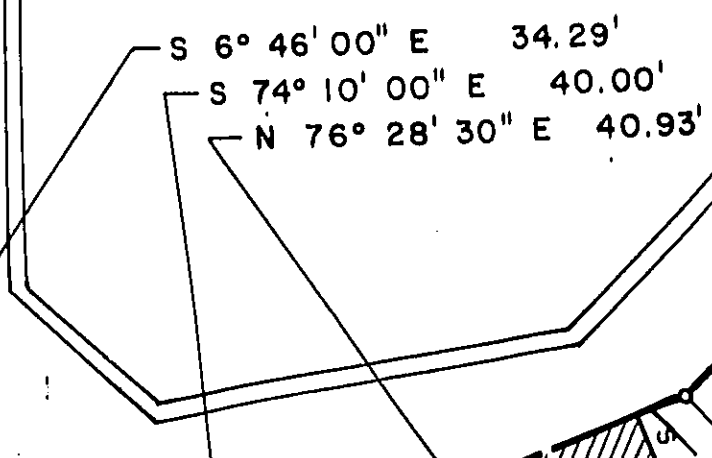

CAMELOT TOWNHOMES TRACT
COMMON AREA 1.231 Ac.

3.161 APODK 040 PAGE 1897

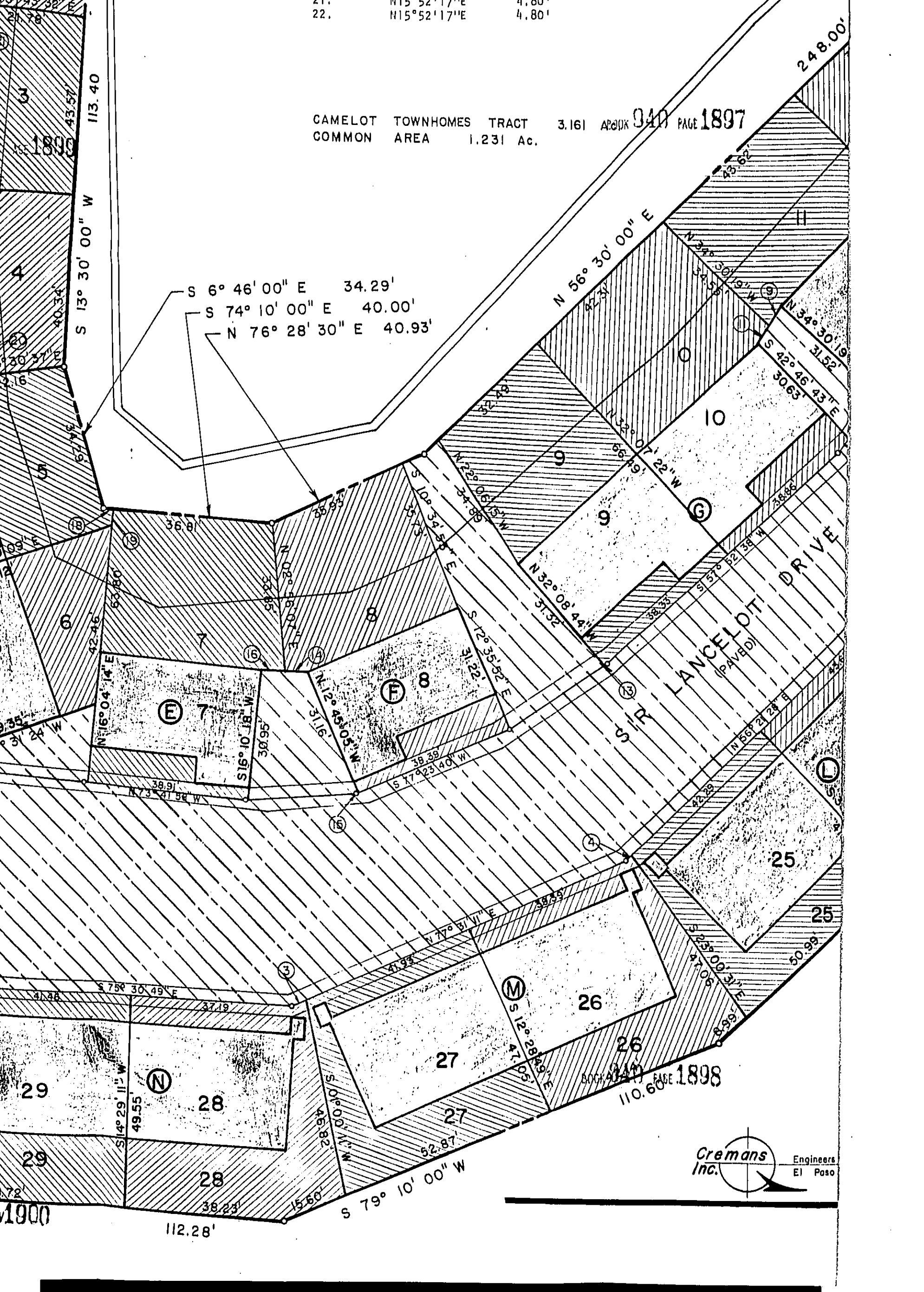

Cremans
Inc. Engineers
El Paso

1900

110.60' PAGE 1898

112.28'

N.W. COR.
LOT 8
CAMELOT
HTS.

POINT OF BEGINNING

S 82° 56' 00" E
287.06'

S 82° 56' 00" E
63.75'

94.00'

30.25'

SCALE 1"=20'

220.77'

173.73'

IA

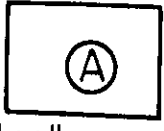

S 77° 00' 46" E
50.02'

9.04'

N 66° 11' 30" E
33.16'

S 77° 00' 46" E
51.96'

38.58'

N 12° 56' 19" E
43.88'

30.75'

N 77° 12' 13" W
30.74'

S 78° 43' 32" E
21.78'

S 78° 43' 32" E
30.74'

S 78° 21' 50" E
51.46'

38.45'

N 10° 28' 10" E
36.42'

30.45'

N 78° 26' 38" W
27.16'

S 86° 30' 57" E
22.16'

N 81° 25' 59" E
27.67'

N 30° 35' 40" E
47.04'

S 78° 21' 07" E
54.27'

99.28'

50.82'

33

33

49.00'

41.21'

S 17° 38' 53" W
49.00'

N 10° 28' 10" E
36.42'

38.45'

N 77° 12' 13" W
30.74'

N 12° 56' 19" E
43.88'

N 66° 11' 30" E
33.16'

9.04'

4.45'

5

20

40.34'

15.189'

43.57'

29.50'

13.14'

43.92'

13.14'

29.50'

13.14'

43.92'

13.14'

29.50'

13.14'

43.92'

13.14'

29.50'

13.14'

43.92'

13.14'

29.50'

13.14'

43.92'

13.14'

29.50'

13.14'

43.92'

13.14'

29.50'

13.14'

43.92'

EXHIBIT D
CAMELOT TOWNHOMES

UNIT NUMBERS

PERCENTAGE OF INTEREST IN COMMON AREAS

1	3.030
2	3.030
3	3.030
4	3.030
5	3.030
6	3.030
7	3.030
8	3.030
9	3.030
10	3.030
11	3.030
12	3.030
13	3.030
14	3.030
15	3.030
16	3.030
17	3.030
18	3.035
19	3.030
20	3.030
21	3.030
22	3.030
23	3.030
24	3.030
25	3.030
26	3.030
27	3.030
28	3.030
29	3.030
30	3.030
31	3.030
32	3.035
33	
	100. percent

EXHIBIT D

BOOK 940 PAGE 1901

CL# 305

90.00

300

35947

FILED FOR RECORD
IN THE OFFICE

OCT 9 PM 3:03

EL PASO COUNTY CLERK
S. J. Stuebel

STATE OF TEXAS
I hereby certify that this instrument was filed
on the date and time stamped herein by me and
was duly recorded in the volume and page of the
Official Public Records of Real Property, El Paso
County, Texas.



OCT 9 1978

L. Donna McConell
COUNTY CLERK, El Paso County, Texas

INVESTCO
Return To ATTN: J.P. SORENSON
330 EUBANK CT.
El Paso, Texas 79902

BOOK 910 PAGE 1902